

# Motore Trifase

## THREE-PHASE MOTOR

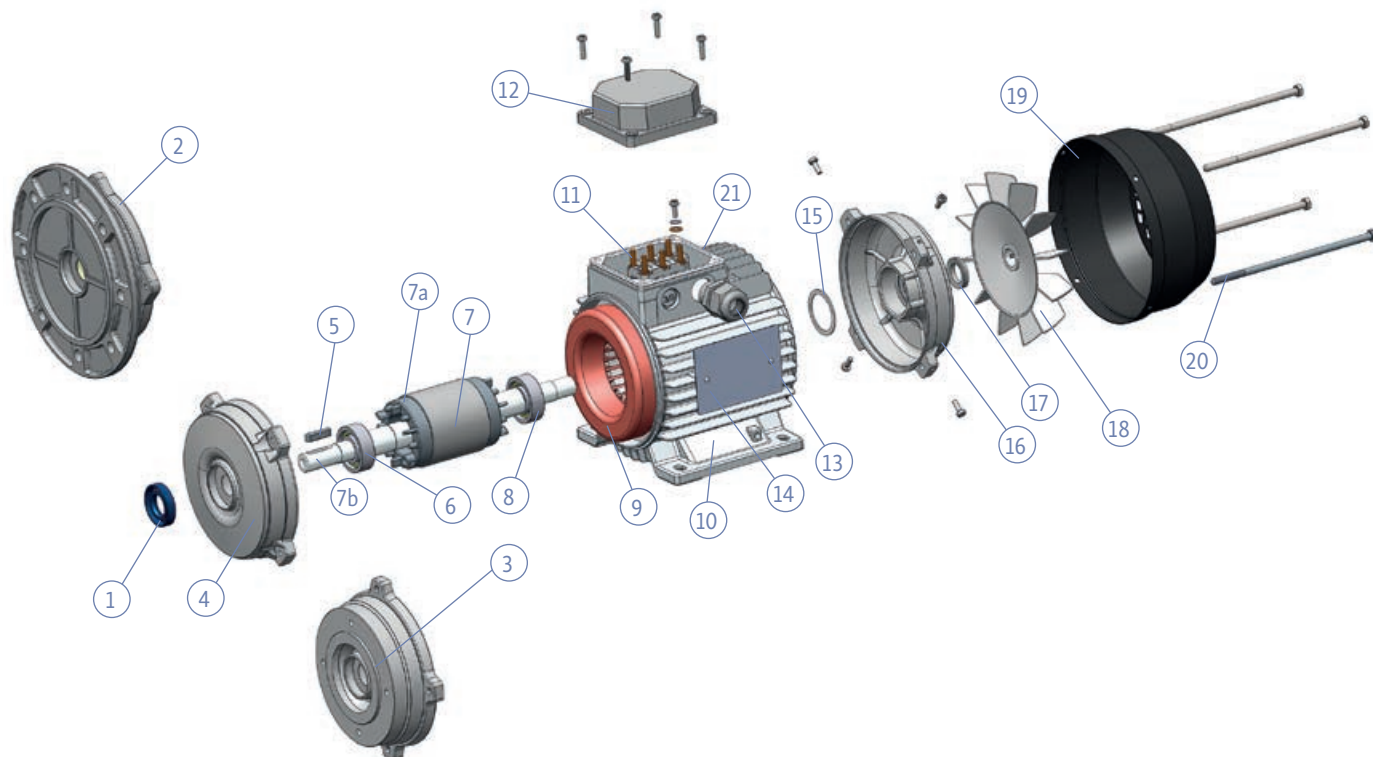

1	Tenuta anteriore	Front Seal
2	Flangia B5	B5 Flange
3	Flangia B14	B14 Flange
4	Scudo anteriore	A-Side Shield
5	Chiavetta	Key
6	Cuscinetto anteriore	A-Side Bearing
7	Indotto	Shaft+rotor
7a	Rotore	Rotor
7b	Albero	Shaft
8	Cuscinetto posteriore	B-Side Bearing
9	Statore avvolto	Stator
10	Carcassa	Housing
11	Morsettiera	Terminal Block
12	Copribasetta	Terminal box
13	Pressacavo	Cable Gland
14	Targhetta	Nameplate
15	Anello di compensazione	Compensation Ring
16	Scudo posteriore	B-Side Shield
17	Tenuta posteriore	Rear Seal
18	Ventola	Fan
19	Copriventola	Fan Cover
20	Tirante	Tie-rod
21	Guarnizione copribasetta	Terminal box seal